

Ref: 60-BD/2025/114

TENDER NOTICE

State Trading Organization Plc invites parties to submit price Proposals / offer to operate commercial units at Male' STO Harbor Food Court Area. (G-01 Block)

State Trading Organization shall endeavor to adhere to the following schedule:

Issuance Tender Notice & RFP	15 th April 2025	Tender Notice and RFP Published on Government Gazette, and STO Website (www.sto.mv)
Site visit	17 th April 2025 & 19 th April 2025 11:00hrs to 12:00hrs Contact person: Hamdoon Contact number: 9994262	Block G-01, Ameenee magu
Inquiries period	16 th April 2025 to 28 th April 2025, 15:00hrs	Enquiries to be sent to admin.properties@sto.mv Tel: +960 3344275 / +960 3344134 <i>Queries received after the deadline will not be attended</i>
Submission & Opening of Proposals	29 th April 2025, 11:00hrs	Proposals are to be submitted to STO Head Office reception counter before the deadline. Proposals shall be opened in front of the proponents that choose to be present

REQUEST FOR PROPOSAL

LEASING OF COMMERCIAL UNITS AT STO HARBOR FOOD COURT AREA



evolving with you

STATE TRADING ORGANIZATION PLC.

15th April 2025

1. INTRODUCTION

State Trading Organization PLC (STO) invites to submit price proposals / offer to operate commercial units at Male' Harbor Food Court Area.

Interested parties should submit price proposals / offer in compliance with the terms described in this RFP.

2. SCHEDULE OF BIDDING PROCESS

State Trading Organization shall endeavor to adhere to the following schedule:

Issuance Tender Notice & RFP	15 th April 2025	Tender Notice and RFP Published on Government Gazette, and STO Website (www.sto.mv)
Site visit	17 th April 2025 & 19 th April 2025 11:00hrs to 12:00hrs	Block G-01 Ameenee magu Contact person: Hamdoon Contact number: 9994262
Inquiries period	16 th April 2025 to 28 th April 2025, 15:00hrs	Enquiries to be sent to admin.properties@sto.mv Tel: +960 3344275 / +960 3344134 <i>Queries received after the deadline will not be attended</i>
Submission & Opening of Proposals	29 th April 2025 ,11:00hrs	Proposals are to be submitted to STO Head Office reception counter before the deadline Proposals shall be opened in front of the proponents that choose to be present

3. TERMS OF LEASE

- 3.1. The lessee would be required to develop and operate the provided commercial unit area according to the guidelines below.
- 3.1.1. The allocated unit area should only be used for commercial activities, such as a shop, office or service outlet.
- 3.1.2. The allocated unit area is strictly prohibited to use as café/ restaurant and storage/ warehousing.
- 3.1.3. Lessee must not make any changes to the premises that have not been approved by STO.
- 3.1.4. Lessee must submit details of any proposed changes and obtain written approval from STO before making any changes to the premises.
- 3.2. Maintenance fee would be charged at the rate of MVR 5.30 per sq. feet for the following services provided by STO:
- Cleaning, repair & maintenance of common area.
 - Cleaning & maintenance of toilets and wash areas.
 - Security services for after business hours.
 - Servicing fire safety equipment.
 - Garbage disposal service.
- 3.2.1. Cleaning of common area will be done on a daily & weekly scheduled basis.
- 3.3. All areas of the premises are non-smoking zones.
- 3.4. Lessee shall be responsible for any damages caused by negligence, loss, or wear beyond normal usage.
- 3.5. A joint inspection will be made by STO and the selected party prior to implementation of operations. The inspection shall be documented and signed by lessee and STO. A similar inspection shall be made before 3 (three) months from contract completion or at any time within contract duration.
- 3.6. Lessee must meet all required sanitation and safety standards including compliance with applicable health codes, fire safety codes and shall obtain all required certifications and licenses. Certifications and licenses must be displayed in the designated area and copies of all such certifications must be submitted to STO prior to commencement of operations.
- 3.7. STO reserves the right of prior approval of all signage, posters or advertisements placed on the building premises.
- 3.8. Units cannot be subleased.
- 3.9. Unit lease rights cannot be transferred.
- 3.10. Period of lease
- a) The units will be leased for 2 (two) years with the possibility of extension.
- 3.11. Duties of lessee

- a) Units shall be only used only be used as other commercial activities other than café/ restaurant and storage/ warehousing use.
- b) Lessee must be responsible to pay for the utilities of the unit.
- c) Lessee must not make any use of electrical outlets/ports installed in the common area.
- d) Lessee must arrange to properly pack and transfer all garbage and waste items to the designated garbage area. Such items shall not be kept elsewhere.

4. UNIT DETAILS & BASE RATES

Block no.	Wing	Area / SQ Ft	Base Rate per SQ Ft (MVR)
G-01	Ameenee Magu	637.38	40

5. INSTRUCTIONS TO PROPONENTS

- 5.1. **Language of proposal:** The proposal documents must be written in English. The proposal must be written without erasures, both in figures and in words.
- 5.2. **Minimum rate per square feet:** The Minimum rate per square feet must be MVR 40.00.
- 5.3. **Security deposit:** Within 07 (seven) days of Award Notification and prior to execution of the agreement, the party shall pay a security deposit equivalent to 2 (two) months' rent, as security deposit to the STO's proposed Bank account specified in the Award Notification. Failure to pay the security deposit will lead to annulment of the award notification. Security deposit will be retained till contract is terminated or expired. In the event of bid withdrawal after award notification and payment of security deposit, STO will only refund 50% of the security deposit.
- 5.4. **Addenda:** At any time prior to the Bid Due Date, STO may, for any reason, whether at its own initiative or in response to clarifications requested by a Proponent, modify the RFP by the issuance of Addenda. In order to afford the Proponents a reasonable time for taking an Addendum into account, or for any other reason, STO may, in its sole discretion, extend the Bid Due Date.
- 5.5. **One proposal Per Proponent:** Each Proponent must submit only one proposal for the unit. A Proponent who submits or participates in more than one proposal for the unit will be disqualified. If STO discovers or has a reason to believe that collusion exists among any/all Proponents, any/all such proposals will be rejected, and all participants in such collusion will be excluded from consideration for future proposals for the same work.
- 5.6. **Validity:** Proposals shall remain valid for 60 (Sixty) days after the deadline for date of bid submission.
- 5.7. **Right to Cancel or Reject:** STO reserves the right to accept or reject any Bid, and to annul the bidding process and reject all Bids at any time prior to Contract award, without thereby incurring any liability to Proponent. STO reserves the right to reject proposals from Blacklisted Customers and Legal Customers, including the Default Customers/Parties and it shall extend to Subsidiaries of STO as well.
- 5.8. **Applicable Laws and Courts:** This RFP and any resulting contract shall be governed in all respects by the laws of the Republic of Maldives and any litigation with respect thereto shall be brought only in the courts of the City of Male'.
- 5.9. **Right to Verify:** STO reserves the right to verify all statements, information and documents submitted by the Proponent in response to the [the RFP and/or the Bidding Documents] and the Proponent shall, when so required by STO, make available all such information, evidence and documents as may be necessary for such verification. Any such verification, or lack of such verification, by STO shall not relieve the Proponent of its obligations or liabilities hereunder nor will it affect any rights of STO thereunder.

5.10. **Blacklisted and Default Customers:** STO reserves the right to disqualify the bidder and has the right to Blacklist permanently or to suspend the Bidder for a certain period depending on the severity on the following circumstances.

- Intent to cheat and/or history of any such incident with STO;
- Misrepresentation of facts in Bid Proposals and/or history of any such incident with STO;
- Malpractices in supplies or services and/or history of any such incident with STO;
- Intentional Disclosure of STO's confidential information and/or history of any such incident with STO;
- Bidder participates in bidding / Negotiations, wins the contract but subsequently does not execute the work and/or history of any such incident with STO;
- Repetitive Quality issues in Supplies / Services and/or history of any such incident in the past engagements with STO;
- Unreasonable delays in deliveries or execution of services and/or history of any such incident in the past engagements with STO;
- Bidder's repetitive delays getting into contractual agreement with STO after winning a contract and/or history of any such incident in the past engagements with STO;
- Other violations of responsible business practices;
- Any other criteria as STO may deem appropriate in the interest of STO or government in compliance with company policies and Laws of Republic of Maldives.

5.11. **Conflict of Interest:** A Proponent shall not have any conflict of interest that affects the bidding process. Any proponent found to have any conflict of interest shall be disqualified.

5.12. **Verification of Documents:** During the examination of responsiveness, evaluation, and comparison of bids, STO may, at STO's discretion, ask any Bidder to submit any documents (including and not limited to some mandatory documents which shall not affect the competitiveness of the process) for clarification and verification of the Bidder's Bid. Any document which affect the competitiveness shall not be accepted during the resubmission period. The Tender Committee has discretion to reject any document submitted during resubmission period, if found, which shall affect the competitiveness of the Tender process.

6. PROPOSAL PREPARATION

In order to be considered for selection, Proponents must submit a complete set of documents listed below. One (1) original proposal, marked "Original", must be submitted to the address specified in

this RFP. No other distribution of the proposal shall be made by the Proponent. STO shall neither accept oral proposals, nor accept proposals received by telephone, FAX, or electronically.

6.1. Proposal document format

- 6.1.1. Contents should be in the following order & format;
 - a. Document Submission Checklist as provided in Annex 2 of this RFP
 - b. Proposal cover page
 - i. Bid title
 - ii. Proponent name
 - c. Bid Submission Summary Form as provided in Annex 1 of this RFP
 - d. Documents as mentioned in 6.2 of this RFP
- 6.1.2. Page numbers should be included in the format of (Page 1 of 1) on all sheets of the document
- 6.1.3. All sheets must be signed or stamped by the proponent

6.2. Documents to Submit

Proponents shall submit the following documents with the proposal / offer.

Company	Individual party
a. ID card Copies/PP Copies of Shareholders.	a. ID Card Copies/PP Copies of proponent.
b. Memorandum and Articles of Association	b. Guarantor letter. (Annex 4)
c. Board Resolution to participate in the tender.	c. Guarantor ID copy / PP copy.
d. Company registration copy.	d. Past 3 months' bank statement (with bank stamp).
e. Past 3 months' bank statement (with bank stamp) or Audited Financials	e. Business registration copy.

7. SUBMISSION

- 7.1. Deadline for submission is 29th April 2025, 11:00hrs, Maldives Time. Proposal should be submitted to STO Head Office reception counter before the deadline along with required documents, on or before the submission deadline.
- 7.2. Bids received by STO after the specified time on the Bid Due Date shall not be eligible for consideration and shall be summarily rejected.
- 7.3. Resubmission Period;

7.3.1. Bidders shall be notified to submit missing documents required for evaluation, within 48 (forty-eight) hours of the bid submission and failure to re-submit shall result disqualification of the bidder.

7.4. **Legal Clearances:** Bidders shall submit legal clearance forms within given deadline once circulated by STO and failure to submit shall result disqualification of the bidder.

8. EVALUATION CRITERIA

Marks %	Criteria	Details
100	Rent proposed	The highest rate offered will receive the highest marks.

- *If two proponents submit valid proposal to the same unit with same value, the bid would be cancelled and retendered.*

As part of the evaluation process, STO may conduct interviews with the parties submitting proposals.

9. AWARD NOTIFICATIO LETTER

After evaluation & selection process, the selected party would be issued a conditional Award Notification with instructions to pay security deposit within 7 (seven) days. Agreement between both parties would be signed after STO confirms receipt of security deposit.

For the avoidance of any doubt, Award Notification shall not render any binding agreement or commitment with the selected party. STO may at any time, by its own discretion may revoke or cancel the Award Notification Letter without the obligation to provide any justification and incurring any liability whatsoever. For the purpose of this Bidding process, Award Notification shall be considered as a mere notification to sign the Agreement between Parties. Unless and otherwise the parties execute a written Agreement to lease the Unit, no agreement or commitment shall exist between the parties.

In the event the proponent fails to pay security deposit and/or submit legal clearance within the stipulated period; STO reserves the right to cancel the award notification and the next eligible Proponent may be considered.

10. SUBSEQUENT AGREEMENT

A Subsequent Agreement shall be drawn with the selected bidder and this document with all terms and conditions shall form part of the Subsequent Agreement.

Notwithstanding anything to the contrary contained in this RFP, the detailed terms specified in the Subsequent Agreement shall have overriding effect; provided, however, that any conditions or

obligations imposed on the Bidder hereunder shall continue to have effect in addition to its obligations under the Agreement.

11. COMMUNICATIONS

During the RFP process, questions or clarifications about this RFP must be directed by email to:

Business Research & Property Management

State Trading Organization Plc.

Boduthakurufaanu Magu, Male'

Tel: +960 3344275 / +960 3344134

Email: admin.properties@sto.mv

Except as provided in the preceding section relating to questions about this RFP, Proponents shall not contact any officers, employees, or team members of STO with respect to this RFP. Any oral communication with a Client employee concerning this RFP is not binding on Client and shall in no way alter a specification, term or condition of this RFP or any contract documents.

ANNEX

Annex 1: Bid Submission Summary Form

Proponents Details	
Name of the individual or company:	
Address:	
<u>Contact Details</u> Contact no: Fax no: Email Address:	
<u>Primary focal point details</u> Name: Contact no: Email Address:	

Rent Rate Proposed		
Amount of rent proposed per sq. feet for the unit. <i>(refer to clause 5.2)</i>	Proposed rate:	

Stamp & Signature of Proponent:

Annex 2: Document Submission Checklist

If proponent is a company:

Document	Checkmark (✓) by Proponent	Field to be used by STO during bid opening
ID Card Copies/PP Copies of Shareholders		
Memorandum and Article of Association		
Board Resolution to participate in the tender.		
Company registration copy		
Past 3 months' bank statement (with bank stamp) or Audited Financials		
Signature / Stamp on all pages of the proposal		

If proponent is an individual:

Document	Checkmark (✓) by Proponent	Field to be used by STO during bid opening
ID Card Copies/PP Copies of proponent		
Guarantor letter		
Guarantor ID copy / PP copy		
Past 3 months' bank statement (with bank stamp)		
Business registration copy.		
Signature / Stamp on all pages of the proposal		

Annex 3: Site Layout

NORTH



AMEENEE MAGU
ROAD WIDTH = 30 FEET

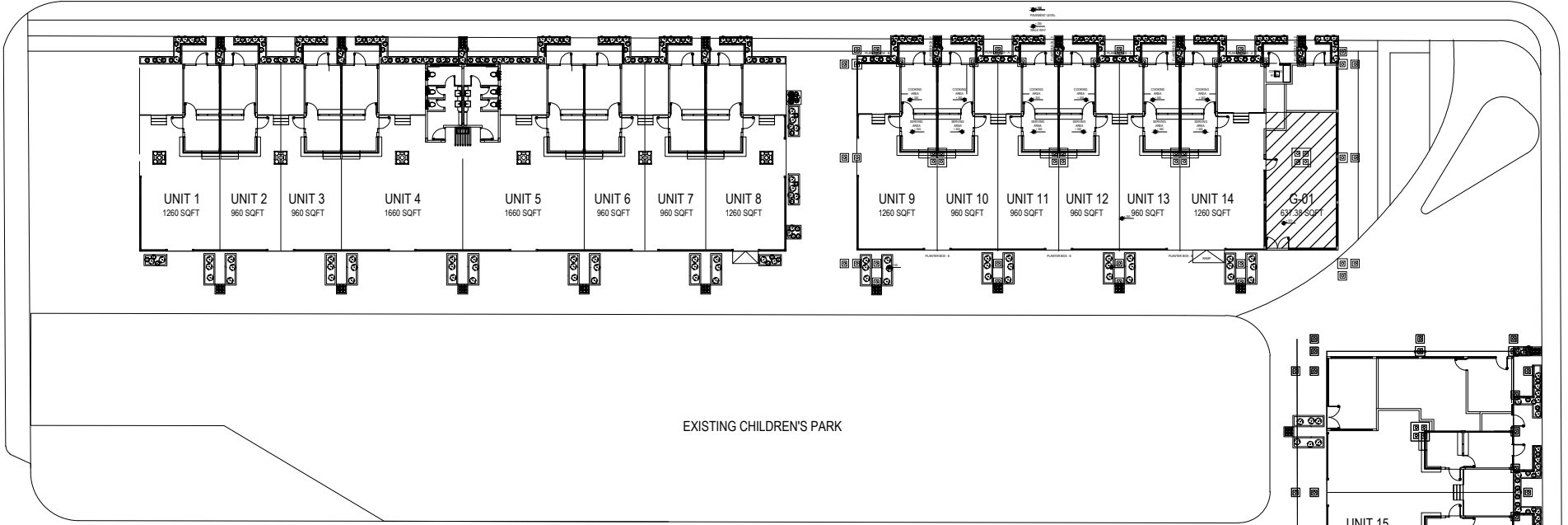

FOOD COURT OVERALL FLOOR PLAN

SCALE 1:500

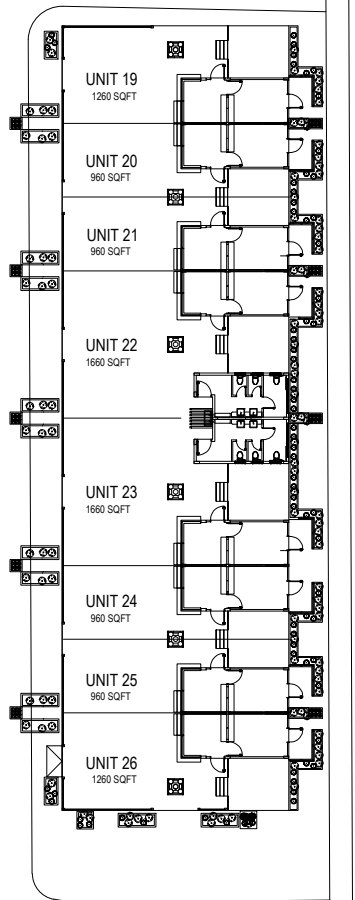
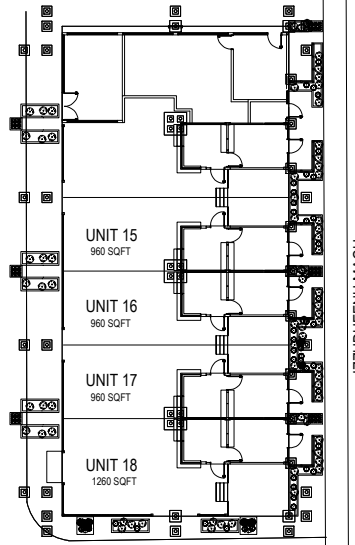

IZZUDHEENU MAGU
ROAD WIDTH = 25 FEET

Annex 4: Guarantor Letter

Address,
Road
Male,

Date

The Manager,
Business Research & Property Management,
State Trading Organization Plc.
Boduthakurufaanu Magu, Male'

RE: GUARANTOR FOR INDIVIDUAL BID SUBMISSION TO LEASE HARBOR FOOD COURT

I [] the undersigned, in response to the proposal submitted by Mr/Miss *[insert proponent name]*, hereby irrevocably provide this Guarantee Letter with reference to the Request for Proposal (the "RFP") for the lease of commercial unit at STO Harbor Food Court Area.

Accordingly, I, [], in my personal capacity, accept and agree to be a Guarantor for Mr/Miss *[insert proponent name]*, in undertaking this opportunity. As such, I assure that Mr/Miss *[insert proponent name]* will be able to financially commit to that Security Deposit of 2 (two) months' rent for his/her desired unit and that he/she is capable to undertake the operations as outlined in his/her proposal/agreement.

In the event Mr./Miss *[insert proponent name]* fails to fulfill his/her outlined commitments and financial obligations under any agreement with STO, I, [] serve irrevocable Guarantee to STO to undertake and pay to STO on first written demand the amount STO state that Mr/Miss *[insert proponent name]* owes and I further guarantee that no obstacle shall pass in having to face any negative consequence because of him/her not being able to fulfill his/her terms, for I shall severally undertake any such responsibility on behalf of Mr/Miss *[insert proponent name]* .

If you wish to require any clarification, please do not hesitate to contact me on *(insert contact number)*

Thanking you.
Sincerely,

Name,
ID Card number